

# Grinding Mills



- Traylor
- Vecor



# Background

## About FLSmidth Minerals

FLSmidth Minerals is your One Source, One Partner for mining and minerals processing equipment and services. Utilizing the latest in technology, resources, and materials, our engineered solutions provide you with the ideal design, equipment, and process support for your systems.

Behind our organization is Denmark-based FLSmidth, an international group of companies delivering equipment, systems, and high technology engineering services for the cement and minerals industries. This dedicated focus and international scope provide FLSmidth – and FLSmidth Minerals – a solid foundation. When you select FLSmidth Minerals as your partner, you also bring this solid foundation and support to your business.

To successfully operate in today's challenging economy, companies require innovative solutions to make their plant operating systems function at peak efficiency. Making use of the latest in equipment technology, resources and materials, FLSmidth Minerals utilizes engineered solutions to help our customers find the optimum designs, equipment sizes and process support for their systems.

FFE Minerals (Pty) Limited was established in 1997 under the Fuller Brand Name. The Fuller name has subsequently been changed, and the company is now a member of the FLSmidth Minerals Group of Companies, thus maintaining a long and rich history in the design and supply of top quality grinding mills.

Grinding mills supplied by FLSmidth Minerals have their origins dating back to the Fuller Company, based in Bethlehem, Pennsylvania, USA. Fuller has been a leading supplier of grinding mills under the Traylor brand name since 1902 and many of the largest plants operating today have these world renowned SAG and Ball Mills operating in some of the most extreme environments. The Vanderbijl Engineering Corporation (VECOR) was

established in South Africa in 1949 and is a wholly owned brand of FLSmidth Minerals that traditionally supplied mills to Sub-Saharan Africa.

Since acquiring Vecor, FLSmidth Minerals has been closely linked to the growth of the mining industry throughout Africa, and particularly in South Africa. Our inventive nature and versatile design methods have pioneered the development of a variety of technologies such as shell supported and open-end discharge SAG Mills.

FLSmidth Minerals' well-established background, together with the supply reference of over 2500 mills, which include many „World Firsts“, has placed the company in a leading position within the field of Grinding Mill Technology.

In addition to this, our Customer Service Department (CSD) has assisted with the inspection and maintenance of installed mills and supplied the necessary spares and installation expertise required to preserve the quality of the operating mill. They have also been extensively involved in the dismantling, refurbishment, relocation and recommissioning of used mills.



SAG Mill at Amandelbult Platinum Mine, South Africa (6,1m x 8,2m dia)

# Milling Systems

FLSmidth Minerals design and supply the entire group of principal milling systems.

These include:

- Autogenous
- Semi-Autogenous (SAG)
- Ball
- Rod
- Pebble Mills

These mills can be supplied individually or as a package depending on the requirements of the client. A large number of SAG Mills have been supplied to the mining industry, of which 25% are of the innovative open-end discharge design supported on slipper pad bearings.

FLSmidth Minerals have a range of mills that can be delivered and custom designed to suit various conditions as well as client preferences including the accommodation of a variety of drive arrangements, bearing types and common spares.

## Drive arrangements available include:

- Direct drive systems utilizing slow speed synchronous motors with air clutches or modern PWM drives
- Drives through reduction gearboxes
- Dual pinion drives
- Wrap around motors for increased power draw on larger mills

## Bearing designs available include:

- Hydrostatic trunnion supported sleeve bearings
- Hydrodynamic trunnion supported sleeve bearings
- Hydrodynamic tilting pad, shell supported bearings
- Hydrostatic multipad bearings



## Designs are available for a huge range of milling systems including:

- Ball mills up to 8,23 m in diameter
- SAG mills up to 12,2 m in diameter
- Conventional geared drives for transmitting up to 15,000 kW of power by use of a twin pinion system
- Gearless drives supplied in excess of 25,000 kW

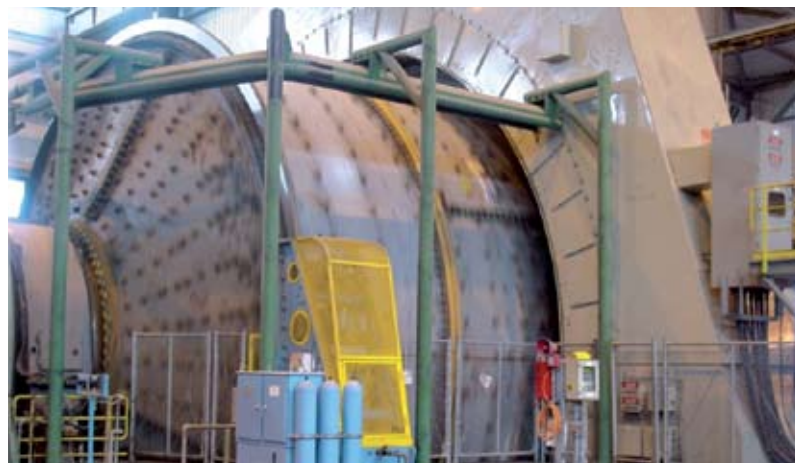

SAG Mill at Compania Minera Antimina, Peru

# Design Methods & Cost Savings

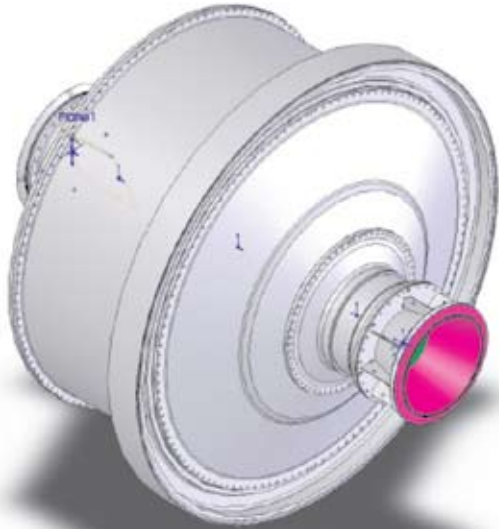

Our design team has pioneered and perfected various mill configurations.

The team consists of an Engineering Manager, Design Engineers, Drawing Office Manager, Chief Draughtsmen and various draughtsmen. Their focus is the continual upgrade of our engineering designs, proving that we are committed to offering our clients the most cost effective engineering solution at all times.

During the design process extensive use is made of our in-house finite element stress analysis facility. This is a software simulation of the rotating mill, with the main model including all geometric details necessary to complete a comprehensive stress analysis. Our design package also accommodates larger components thus not limiting the design in any way.

Our modern Finite Element Design approach together with decades of in-house experience and design information, backed with field strain gauge tests, has provided many satisfied customers with equipment that has an unbeaten record of reliability and exceptional availability.

FLSmidth Minerals' policy of "designed for manufacture and fitness for purpose" is employed to ensure a balance of reliability and cost competitiveness.

In the ever-increasing quest for reduced mineral processing costs and increased throughput tonnages, there has been a worldwide move towards larger and larger mill sizes. It is thus no surprise that we have been associated with the supply of some of the world's largest wet ball mills measuring 8,23 m in Diameter and 13,10 m long with an installed

power of 18,650 kW, as well as the supply of SAG mills up to 12,2 m in diameter.

With our expertise, experience and continual plant data updating systems we are pleased to be able to claim an unequal history of success. Our equipment has met its intended production duty in all instances, thus yielding economies of scale without sacrificing reliability.

Common spares associated with a central stores system become an important aspect of capital cost saving for any new project. For this reason our milling systems can be designed to accommodate equipment types common to existing operations within any mining group.

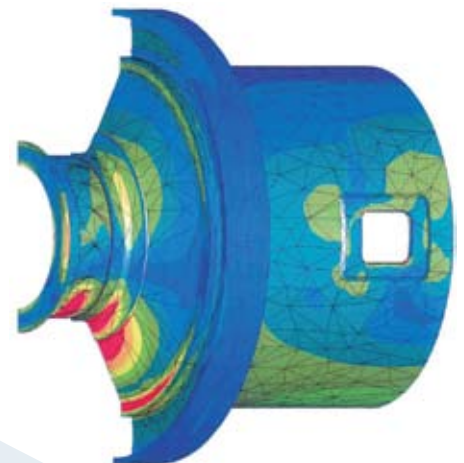

FEA on a large diameter SAG Mill

# Scrubbers & FT Series

In addition to the more common grinding mill applications, FLSmidth Minerals is a leader in the supply of scrubbers to the international diamond industry.

These scrubbers are designed

- To cater for all fixed location diamond scrubbing applications
- For both small operations and large capacity multi-stream diamond developments
- With diameters up to 7,32 m and are available on shell supported bearings or riding ring and roller support systems

Whatever your capacity requirement or budget demands, FLSmidth Minerals can offer a technically superior, financially competitive solution.

Mills ranging from 1,6 m through 4,3 m in diameter have been grouped together under the FT Series range.

FLSmidth Minerals developed these mills to support today's market requirements of:

- Shorter Delivery Times
- Cost Effective Solutions
- Cost Efficient Operation

Although they are standardized, these mills continue the tradition of robust designs and result in quick turn-around times, improving equipment deliveries as well as increased parts availability.

The design features cast mill heads with integral trunnions. The main bearings include removable bronze inserts for simplified maintenance and feature hydrodynamic lubrication for cost efficient operation.



*Scrubber shell for Inco, Goro (16,7 m x 7,33 m dia.)*



*FT Series Mill at Conda Phosphate, USA (3,7 m x 6,5 m dia.)*



*Scrubber at Finch Diamond Mine, South Africa (4 m x 7,4 m dia.)*

# Shell Supported



*SAG Mill Deelkraal Gold Mine, South Africa  
(4,9 m 12,2 m dia.)*



*Shell Supported SAG Mill Kopanang Gold  
Plant, South Africa (4,9 m 9,15 m dia.)*

The ever-increasing demand for larger diameter mills meant that designers had to employ new methods to compensate for the increased shell stresses associated with the increase in mill size. It was then recognized that there were mechanical advantages to supporting mill shells inboard of the ends, thus reducing the unsupported beam length and high stresses at the junction of the mill shell heads.

FLSmidth Minerals developed their first shell-supported mill in 1978. The slipper pad bearing was first installed and proven in the cement industry, where the environment was extremely harsh. The bearing design, developed totally in-house, has proven itself to be particularly resilient to contaminated lubricants and dirty conditions and has not experienced a single failure attributable to bearing design.

Additional advantages of the shell-supported design were that the mill ends were free of bearings, allowing flexibility of access during relining of the mill and adjustment to the discharge end configuration.

This results in metallurgical freedom and a means of adjusting the process to ensure better performance.

This reasoning resulted in the development of the first open end discharge head, allowing the mill to operate with a grate at variable overflow heights that can be adjusted by the operator.

The shell supported slipper pad bearings are not limited to larger mill applications and have been successfully applied, in a simplified form, to smaller mill types. An example would be the 1.5 m diameter lime slakers operating in the municipal water supply industry in South Africa.

# Customer Service

FLSmidth Minerals offers comprehensive services designed to assist the client in any way possible.

These services include:

- Order of Magnitude/budget estimates for pre-feasibility studies.
  - Design Audits and Feasibility studies including Ore testing and laboratory determinations of the Work Index and type of mill loading required for application (i.e. Rods or Balls). Liberation tests, impact tests, abrasion tests, ore density tests, microscopy and any other testing methods specifically required by the client can also be recommended.
  - Pilot milling operations either in Sizing and selection of the correct milling equipment based on the pilot milling or laboratory information gathered, mathematical models and experience gained in the last 100 years.
  - Pricing and packaging of a milling systems to suite the client's requirements.
  - Design, planning, fabrication, project management and ISO accredited internal quality control systems to ensure the highest quality standards at all times.
  - Full turnkey solutions from installation and commissioning of new equipment.
  - Inspections, service contracts and on site change outs as well as supply of high quality spare parts. FLSmidth Minerals will provide you with value added engineering for your minerals processing operation.
- Breakdown support
  - Operation and Maintenance of the milling plant offering an additional value added service, saving you money by decreasing down time & increasing efficiency.
  - Stripping, inspection, refurbishment, relocation and re-commissioning of used mills.
  - Supply and replacement of worn components.
  - Retrofits and modifications to improve mill functionality and efficiency.
  - Training of maintenance and operational staff.



# Your Partner in Grinding Technology



**FLSMIDTH**  
**MINERALS**  
[www.FLSmidthMinerals.com](http://www.FLSmidthMinerals.com)

**FLSmidth Minerals (Pty) Ltd.**  
c/o Constantia Boulevard &  
Albert Schweitzer Streets  
Constantia Kloof  
Weltevreden Park 1715  
Gauteng, South Africa

Tel.: +27 (0)860 035 792  
Fax: To be advised  
E-mail: [FLSM-za@flsmidth.com](mailto:FLSM-za@flsmidth.com)

©FLSmidth Group 2008. All rights reserved. This brochure makes no offers, representations or warranties (express or implied), and information and data contained in this brochure are for general reference only and may change at any time. Please contact FLSmidth Mineral for specific information or data that may relate to your interests